

DIAPHRAGM SEAL

SLIP RING COUPLED TYPE



IPS-DS-10

SPECIAL FEATURES

- DIAPHRAGM DIRECTLY WELDED TO TOP CHAMBER
- EASY TO CLEAN
- EASY TO CHANGE PROCESS CONNECTION / BOTTOM CHAMBER

APPLICATIONS

DIAPHRAGM SEALS ARE PROVIDED IN THE INSTRUMENTS LIKE PRESSURE GAUGES, SWITCHES, TRANSMITTERS IN ORDER TO ISOLATE THE SENSING ELEMENT FROM THE MAIN SERVICE DUE TO ITS CORROSIVE, VISCOUS AND SEDIMENTED NATURE AND TO AVOID CLOGGING AND SOLIDIFICATION. THESE KIND OF SEALS ARE WIDELY USED IN THE VISCOUS & CORROSIVE SERVICES WHERE FLUSHING IS REQUIRED PERIODICALLY & FREQUENTLY.



SPECIFICATIONS

STANDARD VERSION

Range	: -1 to 0 kg/cm ² & 0 to 70 kg/cm ² (Standard)
Process Temperature	: -40°C to 200°C or as per fill fluid
Instrument Connection	: ½" BSP (F)
Process Connection	: ½" BSP (M)
Fill fluid	: Silicon Oil - DC 200
Mounting	: Direct (Without capillary)

Diaphragm	: AISI 316L SS
Top Chamber	: AISI 304 SS
Bottom Chamber	: AISI 316 SS
Nuts / Bolts	: Steel (Plated)
Sealing Gasket	: PTFE
Tension Flange (Cup type)	: Steel (Plated)

DIMENSIONS - STANDARD VERSION

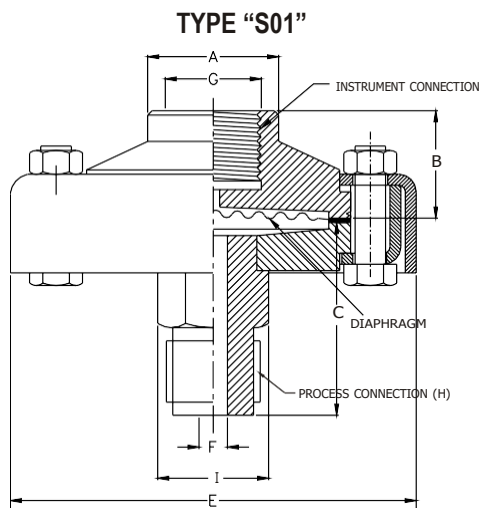

Diaphragm Size	A	B	C	E	F	G	H	I	Approx. Wt.#
63 mm	30	27	45	93	6	½" BSP(F)	½" BSP(M)	HEX A/F 22	1250.0

(# Weight in grams with box for Standard Model.)

Notes : • Drawings are not to scale. • All Dimensions are in mm.

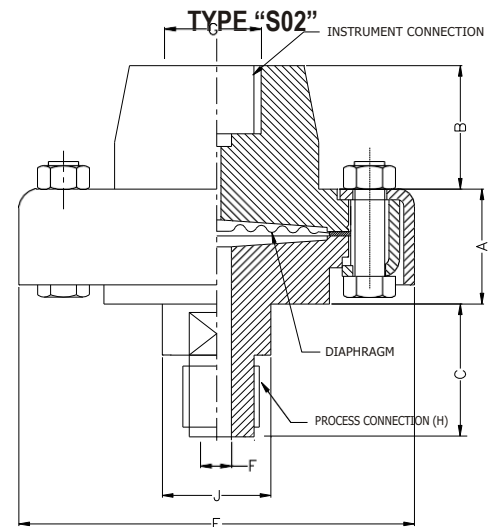

Diaphragm Size	A	B	C	E	F	G	H	J	Approx. Wt.#
63 mm	27	29	32	93	6	¼" BSP(F)	½" BSP(M)	25	1250.0

(# Weight in grams with box for Standard Model.)



Industrix Precise Solutions Private Limited

Room No – 303, Bhumika Residency, Plot No-21, Sector-20, Roadpali, Kalamboli, Panvel (Tal.), Raigad (Dist.), Maharashtra, India – 410218.

Mobile: +91 99309 98399 / +91 99674 97447

E-mail: admin@ipspl.in / sales@ipspl.in Website: www.ipspl.in

CIN : U52399MH2021PTC368555

HOW TO ORDER

BASIC MODEL

CODE

OPTIONAL EXTRAS

[It is recommended that the MOC of Diaphragm should be equivalent or superior than the MOC of Bottom chamber.]

SEAL TYPE

S01 -1 to 0 kg/cm² & 0 to 70 kg/cm² (Standard) **S02** -1 to 0 kg/cm² & 0 to 70 kg/cm² (Standard)

INSTRUMENT CONNECTION

VN 1/4" BSP(F) **VP** 3/8" BSP (F) **VL** 1/2" BSP (F)(Standard) **VM** 1/2" NPT (F) **VO** 1/4" NPT (F)

TOP CHAMBER

XW AISI 304 SS (Standard) **YA** AISI 316L SS **XY** AISI 316 SS

DIAPHRAGM (* Range up to 21 kg/cm²)

UJ AISI 316L (Standard) **UL** HASTELLOY 'C' **UR** TITANIUM **UW** INCONEL 600
UM MONEL **UP** SILVER* **UQ** TANTALUM **UL** HASTELLOY 'C'

SEALING GASKET

VI PTFE (Standard) **YR** METAL

BOTTOM CHAMBER

TM AISI 316 SS (Standard) **UD** TANTALUM **UH** TITANIUM
TL AISI 316L SS **TT** HASTELLOY 'C' **TX** MONEL

PROCESS CONNECTION

WY 1/4" NPT(M) **WT** 3/8" BSP(M) **WR** M20 x 1.5(M)
WA 1/2" NPT(M) **WU** 1/2" BSP(M)(Standard)
WK 3/4" NPT(M) **WF** 3/4" BSP(M)

Note : Other connections like Metric/ PT/ PF/ G/ R etc can be provided on request. Please consult factory.

TENSION FLANGE & NUT - BOLTS (*Nut & Bolts will be AISI 304 SS)

XS STEEL - PLATED (Cup type) (Standard) **XQ** AISI 304 SS **XR** AISI 316 SS*

PROTECTION ON WETTED PARTS (* With bore diameter 10 mm minimum & for connection size 1/2" & above only.)

VS PTFE LINING ON BOTTOM CHAMBER - 2 mm THICK (Max. Up to 150 °C)*
VV PTFE PROTECTION FOR DIAPHRAGM (Max. Up to 150 °C) (Suitable for Pressure Ranges only)
VZ PTFE COATING ON DIAPHRAGM (Max. Up to 315 °C)

FILLING FLUIDS (* Consult factory for specifications, price and delivery.)

US FLUROLUBE 4.2 [-45 to 175 °C] **UY** SILICON DC 704 [10 to 337 °C]
UT FLUROLUBE 6.3 [-40 to 235 °C] **UZ** SILICON DC 710 [7 to 371 °C]
UU FLUROLUBE FS-5 [-28 to 148 °C] **VA** SYLTHERM 800 [-40 to 315 °C]
UV FOOD GRADE OIL [-20 to 140 °C] **VB** SYLTHERM XLT [-100 to 260 °C]
UX SILICON DC 200 [-40 to 205 °C] (Standard) **VC** HALOCARBON OIL*

REMOTE MOUNTING (With capillary of Max. Up to 3 Mtrs.)

SPECIFY IN METERS (e.g. 1.5 = 1.5 METERS 2.0 = 2 METERS)

CAPILLARY

PE AISI 304 SS **PG** AISI 316 SS

CAPILLARY COVERED WITH ARMOUR (Applicable with PE or PG if selected)

PF AISI 304 SS **PH** AISI 316 SS **PI** PVC (Ambient Temp. Max. 60°C)

OTHER OPTIONS

TB HELIUM LEAK TEST **TC** DRY SEAL ONLY WITHOUT INSTRUMENT **GH** MATERIAL TEST CERTIFICATES*

* MATERIAL TEST CERTIFICATES WILL BE PROVIDED FOR WETTED PARTS ONLY WITH CHEMICAL COMPOSITION TESTING. FOR OTHERS, PLEASE CONSULT FACTORY.

Note : Specifications and dimensions given in this product catalogue represents the state of engineering at the time of printing.

Modifications may take place and materials specified may be replaced by others without prior notice.

XXX

XX

XX

XX

XX

XX

XX

XX

XX

XX

3Mtr.

XX

XX

XX

