

INSTRUMENTATION VALVES



MULTI PORT VALVE (Hard Seat)

Type multiport gauge valves are ideal for use on gauge or instrument installations without further penetrations of the main piping. A gauge valve with multiple outlets and inlets with in various sizes and connections. The standard three 1/2" NPT female screwed outlet ports offer a flexibility of alternative applications. Available with a male inlet and three female outlet ports or female inlet and three female outlets. Bleed valves and plugs to suit outlet ports supplied optional.

IPS-NV-03

IPS-NV-04

Technical specifications

Design Pressure	:	6000 PSI
Max temp.	:	240°C
Stem	:	(Type CT) Conical tip press fitted hard chrome plated
Gland Packing	:	PTFE
Stem packing area	:	Burnished finish for smooth valve operation.
Safety Feature	:	Back seating for preventing stem blowout.
Feature	:	Multi outlet design extended valve inlet up to 4" max. for pipe insulation.



Size	Type	Length A	Width B	Height (open) Max., C	Handle D	Handle OD E
1/4"	FxF	74	25	63	40	10
	MxF	84	25	63	40	10
3/8"	FxF	74	25	63	40	10
	MxF	84	25	63	40	10
1/2"	FxF	102	32	83.6	50	11
	MxF	115	32	83.6	50	11
3/4"	FxF	102	38	86.8	50	11
	MxF	115	38	86.6	50	11

All dimensions are in mm

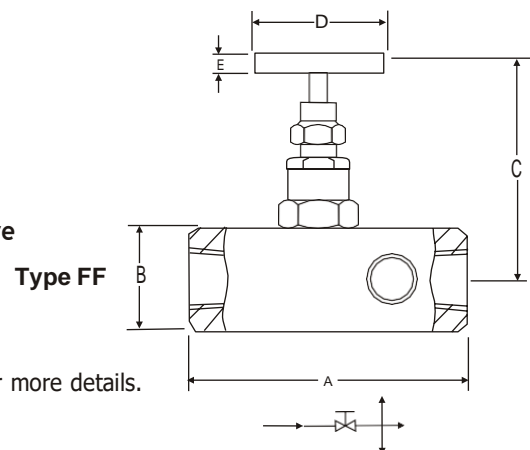
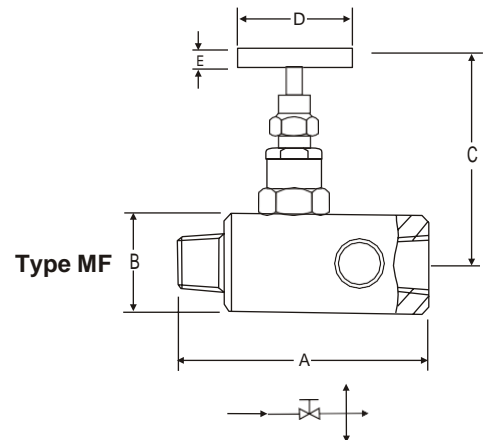

Applications

- Mounting of instruments or multiple gauges
- Instrument isolation
- Instrument installation with separate vents And calibrate connections
- Liquid and vapor gas service

Optional : IPS-NV-10 - High pressure valves for 10,000 psi pressure

Note : Other combination sizes available on request. Please contact us for more details.



Industrix Precise Solutions Private Limited

Room No – 303, Bhumika Residency, Plot No-21, Sector-20, Roadpali, Kalamboli, Panvel (Tal.), Raigad (Dist.), Maharashtra, India – 410218.

Mobile: +91 99309 98399 / +91 99674 97447

E-mail: admin@ipspl.in / sales@ipspl.in Website: www.ipspl.in

CIN : U52399MH2021PTC368555

How to order : IPS-NV-03 IPS-MV-04

IPS-NV-03

IPS-NV-04

Body Material	Stem Packing	Size = P x P1	Connections	Threads
C = Carbon Steel	P = PTFE	24 = 1/4" x 1/4"	FF = Female x Female	N = NPT (ANSI B 1.20.1)
S = SS 316	G = Grafoil	44 = 1/2" x 1/2"	MF = Male x Female	P = BSPP (BS 2779, ISO 228/1)
S4 = SS 304		46 = 1/2" x 3/4"	SW = Socket Weld	B = BSPT (BS 21, ISO 7/1)
SL = SS 316L		64 = 3/4" x 1/2"	FL = Female x extended long body end	
M4 = Monel 400		66 = 3/4" x 3/4"		
M5 = Monel 500				
H = Hastelloy C				

Options -

- IE : Handle circular.
- TF : Compliance to NACE standard MR-0175.
- SG : For Oxygen service, valves are supplied cleaned, degreased and suitably packed.
- GH : Material test certificate
- GO : Hydro test certificate
- BLD8 : Bleeder 1/2" NPT (Male)
- D8 : Plug 1/2" NPT (Male)
- PV : IBR Approval

Example

To place an order simply refer to the codes in the table.

Valve Type : Body Material + Stem Packing + Size + Connection + Threads + Options

Note -

The weld prepared types are available with a male-or-female plain end - suitable for socket weld, or male butt weld end. Always specify pipe schedule and further requirements when ordering valves for welded or Flange connections. Panel mounting option for installation in racks and panels.

Standard Valve Materials

Valve	Body	Bonnet	Stem	Tip
Carbon Steel	CS A105	CS A105	SS 304	SS 304
Stainless Steel	SS 316	SS 316	SS 316	SS 316

